

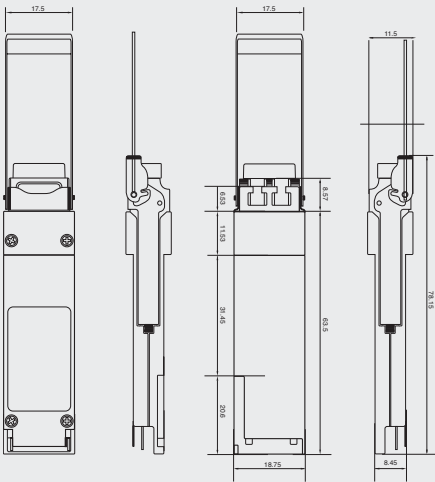

# QSFP28 100G

## Overview

Integra Optics' QSFP28 transceivers are designed in accordance to industry standards and are available in a variety of power budgets and data rate options. Integra QSFP28 transceivers are coded to be 100% OEM compatible and are more than capable of significantly growing network capacity to levels far beyond that of previous generation optical transceivers.



## Features

- Distance Ranging from 100m to 40km
- MM or SM Fiber
- Commercial and Industrial Temperature Ranges Available
- Digital Diagnostics Monitoring Support
- QSFP28 MSA Compliant

## Applications

- 100G Ethernet
- OTN - OTU4
- PAM4 - Single Lambda

## Product Specifications

Integra Part Number	Wavelegnth	Distance	Interface	Description
QSFP28-SR4	850	100/150m	MPO OM3/OM4	QSFP28-100GBase-SR4
QSFP28-eSR4	850	150/200m	MPO OM3/OM4	QSFP28-100GBase-SR4
QSFP28-DR	1310	500m	LC/SMF	QSFP28-100GBase-DR
QSFP28-CWDM4	1310 <sup>1</sup>	2km	LC/SMF	QSFP28-100GBase-CWDM4
QSFP28-FR	1310	2km	LC/SMF	QSFP28-100GBase-FR
QSFP28-LR4	1310 <sup>2</sup>	10km	LC/SMF	QSFP28-100GBase-LR4
QSFP28-LR4(OTU4 Operation)	1310 <sup>2</sup>	10km	LC/SMF	QSFP28-100GBase-LR4(OTU4)
QSFP28-ER4L	1310 <sup>2</sup>	30/40km <sup>3</sup>	LC/SMF	QSFP28-100GBase-ER4L

\*Note 1: Typical output value is -1dBm, giving a typical Power Budget of at least 13.4dB.

\*Note 2: Typical output value is -1dBm, giving a typical Power Budget of at least 14.8dB.

\*Note 3: Certified distance is 30km without FEC, 40km with FEC.

## Did You Know?

You can ensure coding accuracy and eliminate time spent finding replacement optics when you choose Integra transceivers. Our Smart Coder allows technicians to reconfigure our transceivers for specific hardware right in the field.

## QSFP28-SR4

### Detailed Specifications

Parameter	Minimum	Typical	Maximum	Unit
Storage Temperature (Ts)	-40	-	85	°C
Operating Case Temperature CTemp (Tc)	0	-	70	°C
Wattage	-	-	3.5	W
Power Supply Voltage (Vcc)	3.135	3.3	3.465	V
Power Supply Current (Icc)	-	-	1116	mA

### Transmitter

Parameter	Minimum	Typical	Maximum	Unit
Center Wavelength (λC)	840	850	860	nm
Data Rate, per Lane	-	25.78	-	Gbps
ORL Tolerance	-	-	12	dB
Average Output Power (Pout, AVG)	-6	-	2.4	dBm
Extinction Ratio (ER)	3.0	-	-	dB

### Receiver

Parameter	Minimum	Typical	Maximum	Unit
Center Wavelength (λC)	840	850	860	nm
Receive Overload(PMAX)	-	-	-2.4	dBm
Receive Sensitivity (PMIN)	-10.3	-	-	dBm

## QSFP28-eSR4

### Detailed Specifications

Parameter	Minimum	Typical	Maximum	Unit
Storage Temperature (Ts)	-40	-	85	°C
Operating Case Temperature CTemp (Tc)	0	-	70	°C
Wattage	-	-	2	W
Power Supply Voltage (Vcc)	3.315	3.3	3.465	V
Power Supply Current (Icc)	-	-	600	mA

### Transmitter

Parameter	Minimum	Typical	Maximum	Unit
Center Wavelength ( $\lambda_C$ )	840	850	860	nm
Data Rate, per Lane	-	25.78	-	Gbps
ORL Tolerance	-	-	12	dB
Average Output Power (Pout, AVG)	-7.4	-	2.4	dBm
Extinction Ratio (ER)	3.0	-	-	dB

### Receiver

Parameter	Minimum	Typical	Maximum	Unit
Center Wavelength ( $\lambda_C$ )	840	850	860	nm
Receive Overload(PMAX)	-	-	-2.4	dBm
Receive Sensitivity (PMIN)	-10.3	-	-	dBm

## QSFP28-DR

### Detailed Specifications

Parameter	Minimum	Typical	Maximum	Unit
Storage Temperature (Ts)	-40	-	85	°C
Operating Case Temperature CTemp (Tc)	0	-	70	°C
Wattage	-	-	4	W
Power Supply Voltage (Vcc)	3.315	3.3	3.465	V
Power Supply Current (Icc)	-	-	1276	mA

### Transmitter

Parameter	Minimum	Typical	Maximum	Unit
Center Wavelength ( $\lambda_C$ )	1304.5	1311	1317.5	nm
Data Rate	-	100	-	Gbps
Transmit Power AVG (PT)	-2.9	-	4	dBm
Side Mode Suppression Ratio (SMSR)	30	-	-	dB
Optical Modulation Amplitude (POMA)	-0.8	-	4.2	dBm
Optical Return Loss Tolerance	-	-	15.5	dB

### Receiver

Parameter	Minimum	Typical	Maximum	Unit
Center Wavelength ( $\lambda_C$ )	1304.5	1311	1317.5	nm
Receive Power ( $OMA_{outer}$ )	-	-	4.2	dBm
Receive Sensitivity ( $OMA_{outer}$ )	-	-	-3.9	dBm
Receiver Reflectance	-	-	-26	dB

## QSFP28-CWDM4

### Detailed Specifications

Parameter	Minimum	Typical	Maximum	Unit
Storage Temperature (Ts)	-40	-	85	°C
Operating Case Temperature CTemp (Tc)	0	-	70	°C
Operating Case Temperature CTemp (Ti)	-40	-	85	°C
Wattage	-	-	3.5 <sup>1</sup>	W
Power Supply Voltage (Vcc)	3.135	3.3	3.465	V
Power Supply Current (Icc)	-	-	11151	mA

\*Note 1: I-Temp wattage is <4.5w

### Transmitter

Parameter	Minimum	Typical	Maximum	Unit
Lane 0 Center Wavelength (λC0)	1264.50	-	1277.50	nm
Lane 1 Center Wavelength (λC1)	1284.50	-	1297.50	nm
Lane 2 Center Wavelength (λC2)	1304.50	-	1317.50	nm
Lane 3 Center Wavelength (λC3)	1324.50	-	1337.50	nm
Data Rate, per Lane	-	25.78	-	Gbps
Total Average Launch Power (PT)	-	-	8.5	dBm
Average Output Power per Lane (PAVG)	-6.5	-	2.5	dBm
Extinction Ratio (ER)	3.5	-	-	dB
Side Mode Suppression Ratio (SMSR)	30	-	-	dB
Optical Modulation Amplitude (POMA)	-4.0	-	2.5	dBm
Optical Return Loss Tolerance	-	-	20	dB

### Receiver

Parameter	Minimum	Typical	Maximum	Unit
Lane 0 Center Wavelength (λC0)	1264.50	-	1277.50	nm
Lane 1 Center Wavelength (λC1)	1284.50	-	1297.50	nm
Lane 2 Center Wavelength (λC2)	1304.50	-	1317.50	nm
Lane 3 Center Wavelength (λC3)	1324.50	-	1337.50	nm
Receive Overload (P <sub>MAX</sub> )	-	-	2.5	dBm
Receive Sensitivity (P <sub>MIN</sub> )	-11.5	-	-	dBm
Optical Return Loss (DRL)	-	-	-26	dB

## QSFP28-FR

### Detailed Specifications

Parameter	Minimum	Typical	Maximum	Unit
Storage Temperature (Ts)	-40	-	85	°C
Operating Case Temperature CTemp (Tc)	0	-	70	°C
Wattage	-	-	4	W
Power Supply Voltage (Vcc)	3.135	3.3	3.465	V
Power Supply Current (Icc)	-	-	1276	mA

### Transmitter

Parameter	Minimum	Typical	Maximum	Unit
Center Wavelength ( $\lambda_C$ )	1304.5	1311	1317.5	1317.5
Data Rate	-	100	-	-
Transmit Power AVG (PT)	-2.4	-	4	4
Side Mode Suppression Ratio (SMSR)	30	-	-	-
Optical Modulation Amplitude (POMA)	-0.2	-	4.2	4.2
Optical Return Loss Tolerance	-	-	17.1	17.1

### Receiver

Parameter	Minimum	Typical	Maximum	Unit
Center Wavelength ( $\lambda_C$ )	1304.5	1311	1317.5	nm
Receive Power ( $OMA_{outer}$ )	-	-	4.7	dBm
Receive Sensitivity ( $OMA_{outer}$ )	-	-	-4.5	dBm
Receiver Reflectance	-	-	-26	dB

## QSFP28-LR4

### Detailed Specifications\*

Parameter	Minimum	Typical	Maximum	Unit
Storage Temperature (Ts)	-40	-	85	°C
Operating Case Temperature CTemp (Tc)	0	-	70	°C
Operating Case Temperature CTemp (Tc)	-40	-	85	°C
Wattage	-	-	3.5 <sup>1</sup>	W
Power Supply Voltage (Vcc)	3.135	3.3	3.465	V
Power Supply Current (Icc)	-	-	1116	mA

\*Note: I-Temp wattage is <4.5w

### Transmitter

Parameter	Minimum	Typical	Maximum	Unit
Lane 0 Center Wavelength ( $\lambda_{C0}$ )	1294.53	1295.56	1296.59	nm
Lane 1 Center Wavelength ( $\lambda_{C1}$ )	1299.02	1300.05	1301.09	nm
Lane 2 Center Wavelength ( $\lambda_{C2}$ )	1303.54	1304.58	1305.63	nm
Lane 3 Center Wavelength ( $\lambda_{C3}$ )	1308.09	1309.14	1310.19	nm
Data Rate, per Lane	-	25.78	-	Gbps
Total Average Launch Power (PT)	-	-	10.5	dBm
Average Output Power per Lane (PAVG)	-4.3	-	4.5	dBm
Extinction Ratio (ER)	4	-	-	dB
Side Mode Suppression Ratio (SMSR)	30	-	-	dB
Optical Modulation Amplitude (POMA)	-1.3	-	4.5	dBm
Optical Return Loss Tolerance	-	-	20	dB

### Receiver

Parameter	Minimum	Typical	Maximum	Unit
Lane 0 Center Wavelength ( $\lambda_{C0}$ )	1294.53	1295.56	1296.59	nm
Lane 1 Center Wavelength ( $\lambda_{C1}$ )	1299.02	1300.05	1301.09	nm
Lane 2 Center Wavelength ( $\lambda_{C2}$ )	1303.54	1304.58	1305.63	nm
Lane 3 Center Wavelength ( $\lambda_{C3}$ )	1308.09	1309.14	1310.19	nm
Receive Overload (P <sub>MAX</sub> )	-	-	-4.5	dBm
Receive Sensitivity(P <sub>MIN</sub> )	-8.6	-	-	dBm
Optical Return Loss (ORL)	-	-	-26	dB

## QSFP28-LR4 (OTU4 Operation)

### Detailed Specifications\*

Parameter	Minimum	Typical	Maximum	Unit
Storage Temperature (Ts)	-40	-	85	°C
Operating Case Temperature CTemp (Tc)	0	-	70	°C
Wattage	-	-	4.5	°C
Power Supply Voltage (Vcc)	3.135	3.3	3.465	W
Power Supply Current (Icc)	-	-	1435	V

\*Note: I-Temp wattage is <4.5w

### Transmitter

Parameter	Minimum	Typical	Maximum	Unit
Lane 0 Center Wavelength ( $\lambda_{C0}$ )	1294.53	1295.56	1296.59	nm
Lane 1 Center Wavelength ( $\lambda_{C1}$ )	1299.02	1300.05	1301.09	nm
Lane 2 Center Wavelength ( $\lambda_{C2}$ )	1303.54	1304.58	1305.63	nm
Lane 3 Center Wavelength ( $\lambda_{C3}$ )	1308.09	1309.14	1310.19	nm
Data Rate, per Lane	-	27.95	-	Gbps
Total Average Launch Power (PT)	-	-	8.9	dBm
Average Output Power per Lane (PAVG)	-2.5	-	2.9	dBm
Extinction Ratio (ER)	7	-	-	dB
Side Mode Suppression Ratio (SMSR)	30	-	-	dB
Optical Return Loss Tolerance	-	-	20	dB

### Receiver

Parameter	Minimum	Typical	Maximum	Unit
Lane 0 Center Wavelength ( $\lambda_{C0}$ )	1294.53	1295.56	1296.59	nm
Lane 1 Center Wavelength ( $\lambda_{C1}$ )	1299.02	1300.05	1301.09	nm
Lane 2 Center Wavelength ( $\lambda_{C2}$ )	1303.54	1304.58	1305.63	nm
Lane 3 Center Wavelength ( $\lambda_{C3}$ )	1308.09	1309.14	1310.19	nm
Receive Overload (P <sub>MAX</sub> )	-	-	2.9	dBm
Receive Sensitivity(P <sub>MIN</sub> )	-	-	-10.3	dBm
Optical Return Loss (ORL)	-	-	-26	dB



## QSFP28-ER4L

### Detailed Specifications

Parameter	Minimum	Typical	Maximum	Unit
Storage Temperature (Ts)	-40	-	85	°C
Operating Case Temperature CTemp (Tc)	0	-	70	°C
Wattage	-	-	5	W
Power Supply Voltage (Vcc)	3.135	3.3	3.465	V
Power Supply Current (Icc)	-	-	1595	mA

### Transmitter

Parameter	Minimum	Typical	Maximum	Unit
Lane 0 Center Wavelength ( $\lambda_{C0}$ )	1294.53	1295.56	1296.59	nm
Lane 1 Center Wavelength ( $\lambda_{C1}$ )	1299.02	1300.05	1301.09	nm
Lane 2 Center Wavelength ( $\lambda_{C2}$ )	1303.54	1304.58	1305.63	nm
Lane 3 Center Wavelength ( $\lambda_{C3}$ )	1308.09	1309.14	1310.19	nm
Data Rate, per Lane	-	25.78	-	Gbps
Total Average Launch Power (PT)	-	-	12.5	dBm
Average Output Power per Lane (PAVG)	-2.5	-	6.5	dBm
Extinction Ratio (ER)	4.5	-	-	dB
Side Mode Suppression Ratio (SMSR)	30	-	-	dB
Optical Return Loss Tolerance	-	-	20	dB

### Receiver

Parameter	Minimum	Typical	Maximum	Unit
Lane 0 Center Wavelength ( $\lambda_{C0}$ )	1294.53	1295.56	1296.59	nm
Lane 1 Center Wavelength ( $\lambda_{C1}$ )	1299.02	1300.05	1301.09	nm
Lane 2 Center Wavelength ( $\lambda_{C2}$ )	1303.54	1304.58	1305.63	nm
Lane 3 Center Wavelength ( $\lambda_{C3}$ )	1308.09	1309.14	1310.19	nm
Receive Overload (P <sub>MAX</sub> )	-	-	-3.5	dBm
Receive Sensitivity(P <sub>MIN</sub> )	-18.5	-	-	dBm

### Our Mission

Our mission is to ensure that our customers turn up services faster, build out the fiber networks they need to be competitive, and keep them up and running.

## Our Process and Commitment to Uptime

---



Integra Optics is leading the way in uptime. We're innovating the transceiver manufacturing process for more reliable optics and increased availability, from product concept to customer service. We back all of our transceivers with a limited lifetime warranty, and we have designed our process to get the very best transceivers to our customers faster than ever before.

- **Designed for interoperability:** Integra brand transceivers designed and programmed to be 100% interoperable with OEM platform hardware and fully comply with OEM equipment warranties
- **Automated production:** Automated production process in our US facility, using the first high-speed robots in the Western Hemisphere for coding and testing transceivers
- **Accurate coding:** Every transceiver is correctly coded and tested 100% of the time, resulting in optics that are 33 times more reliable than both OEM and third party generics
- **On-demand availability:** We maintain the largest inventory of transceivers in the Western Hemisphere to fill transceiver orders in days rather than the weeks or months, and help customers manage their supply chains.
- **24-hour support:** Experienced customer support team, available 24-hours a day, for technical support and equipment orders
- **A responsive organization:** Unmatched customer service, next-day shipping and even private aircraft to respond to our customers' needs
- **Experienced engineers:** Vast industry experience to help troubleshoot problems, consult on network design solutions and help with turn up
- **ISO Certified:** We hold the ISO 9001:2008 Quality Management System Certification for our dedication to quality in every step of our processes

## Additional Information

---

For more information about Integra Optics' QSFP28 please contact a sales representative at [sales@integraoptics.com](mailto:sales@integraoptics.com) or visit [integraoptics.com](http://integraoptics.com)